

**Product Information for the BBG-8000
VME Serial Protocol Converter**

The BBG-8000 is a multiprocessor based, 6U VMEbus format serial protocol converter. It will operate in a VMEbus backplane or in a stand alone mode requiring only a +5 volt DC power supply.

The BBG-8000 is designed to operate with an eight channel RS-232 serial multiplexor. It provides interfacing to four channels of RS-232, one channel of synchronous MIL-STD-188-114, two channels of RS-422, and one channel of 16 bit discretes.

The four channels of RS-232 conversion support hardware handshaking signals RTS, CTS, DCD, and DTR as well as full duplex signals TXD and RXD.

The asynchronous RS-232 to synchronous MIL-STD-188-114 supports hardware handshaking signals RTS and CTS as well as simplex signals TXD and RXD, and clock signals TXCLK and RXCLK. The TXD and RXD signals have 32 KBit FIFO memory buffers controlled by the respective TXCLK and RXCLK allowing synchronous baud rates of several megabits per second.

The two channels of RS-422 conversion supports hardware handshaking signals RTS, CTS, DCD, and DTR as well as full duplex signals TXD and RXD.

The 12 bit discrete parallel to RS-232 conversion supports TTL level input signals and is factory programmable for user required serial data streams. Serial baud rates are switch selectable for 1200, 2400, 4800, 9600, and 19,200 bits per second.

6U VMEbus FORMAT

**OPERATES IN VMEbus
BACKPLANE OR STAND
ALONE**

**EIGHT CHANNELS OF SERIAL
CONVERSION**

- FOUR RS-232 TO RS-232
- ONE RS-232 ASYNCHRONOUS TO MIL-STD-188/114 SYNCHRONOUS
- TWO CHANNELS OF RS-232 TO RS-422
- ONE 12 BIT PARALLEL TO RS-232

**DUAL MICROPROCESSOR
CONTROLLED**

**KG-84A, KG-84C or KY-100
COMPATIBLE**

**32 KB TRANSMIT AND
32 KBIT RECEIVE FIFOs ON
SYNCHRONOUS INTERFACE**

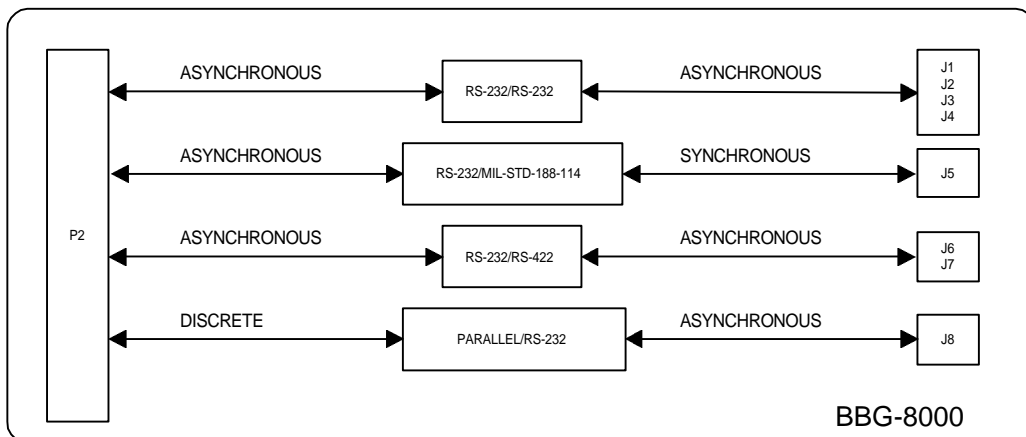

VME PROTOCOL CONVERTER SPECIFICATIONS		
PARAMETER	UNITS	VALUE
POWER SUPPLY	Volts	5
	MiliAmps	500
TEMPERATURE RANGE OPERATING STORAGE	C°	0 to +50
	C°	-65 to +150
PHYSICAL CHARACTERISTICS	in.	9.2 x 6.41 x 0.78
	cm.	23.37 x 16.28 x 1.99

Table 1. VME Protocol Converter Specifications

OVERVIEW

The BBG-8000 VME Protocol Converter is a multiprocessor based, 6U VMEbus format serial protocol converter. The BBG-8000 is designed to operate with an eight channel serial RS-232 multiplexor providing eight channels of serial data interfacing. Four channels provide RS-232 signals, one channel provides RS-232 asynchronous to MIL-STD-188/114 synchronous conversion, two channels provide RS-232 to RS-422 conversion, and one channel provides a parallel to RS-232 conversion. The BBG-8000 operates in a standard VMEbus backplane or in a standalone configuration. Two onboard microcontrollers perform the processing of all signals to provide conversion to user requested outputs.

During power up or reset, the onboard microcontrollers read the configuration switches, configure the interfaces, and provide all signals and control necessary to process the desired interface and output the converted information.

Examples of uses include: navigation systems, communication systems, and industrial control processes.

INPUTS/OUTPUTS

Inputs and outputs are available on the rear 96 pin eurocard connector (P2) and on the front panel high density "D" subminiature connectors. Inputs and outputs are listed below:

RS-232 Interfaces

Four channels of RS-232 data are available on connectors J1, J2, J3, and J4. These channels support modem handshake lines RTS, CTS, DCD, and DTR and full duplex data lines RXD and TXD.

RS-232 Asynchronous to MIL-STD-188/114 Synchronous Interface

One channel of asynchronous RS-232 serial is converted to synchronous MIL-STD-188/114 serial. This channel is available on connector J5. This channel supports modem handshake lines RTS and CTS, half duplex data lines RXD and TXD, and synchronous clock signals TXCLK and RXCLK.

Synchronous baud rate is determined by the input clocks TXCLK and RXCLK. Baud rates up to 4 Megabits per second are supported. Asynchronous serial baud rate selection is determined from the configuration switches at power up or reset. Selectable baud rates include: 1200, 2400, 4800, 9600, and 19,200 bits per second. Default data output is 19200 bps, 8 bits, no parity, and one stop bit (19200, 8, N, 1). Table 2 defines the switch position for the available baud rates.

BBG-8000 BAUD RATE SELECTION								
BAUD RATE (bits per sec)	Configuration Switch S1							
	1	2	3	4	5	6	7	8
1200	1	X	X	X	X	0	1	1
2400	1	X	X	X	X	1	0	0
4800	1	X	X	X	X	1	0	1
9600	1	X	X	X	X	1	1	0
19200	1	X	X	X	X	1	1	1

1 = off, 0 = on, X = Don't Care

Table 2. BBG-8000 Async to Sync Configuration Switch

RS-422 Interface

Two channels of RS-422 data are available on connectors J6 and J7. These channels support modem handshake lines RTS, CTS, DCD, and DTR and full duplex data lines RXD and TXD.

Parallel to Serial Interface

One channel of parallel to RS-232 serial is available on connector J8. This channel reads the parallel data bits on power up or reset and outputs a user defined message over the RS-232 interface.

Asynchronous serial baud rate selection is determined from the configuration switches at power up or reset. Selectable baud rates include: 1200, 2400, 4800, 9600, and 19,200 bits per second. Default data output is 9600 bps, 8 bits, no parity, and one stop bit (9600, 8, N, 1). Table 3 defines the switch position for the available baud rates.

BBG-8000 BAUD RATE SELECTION								
BAUD RATE (bits per sec)	Configuration Switch S1							
	1	2	3	4	5	6	7	8
1200	X	X	X	X	X	0	1	1
2400	X	X	X	X	X	1	0	0
4800	X	X	X	X	X	1	0	1
9600	X	X	X	X	X	1	1	0
19200	X	X	X	X	X	1	1	1
1 = off, 0 = on, X = Don't Care								

Table 3. BBG-8000 Parallel to Serial Configuration Switch

CONNECTOR LIST FOR BBG-8000

CONNECTOR: P1

I/O CONNECTOR TYPE: 96 pin Eurocard Male

CONNECTOR MATE: 96 pin Eurocard Female

PIN NO	SIGNAL	PIN NO	SIGNAL
A1-A8	Not Used	B1-B19	Not Used
A9	GND	B20	GND
A10	Not Used	B21-B22	Not Used
A11	GND	B23	GND
A12-A14	Not Used	B24-B31	Not Used
A15	GND	B32	+5Vdc
A16	Not Used	C1-C8	Not Used
A17	GND	C9	GND
A18	Not Used	C10-C11	Not Used
A19	GND	C12	SYSRST*
A20-A31	Not Used	C13-C31	Not Used
A32	+5Vdc	C32	+5Vdc

CONNECTOR: P2

I/O CONNECTOR TYPE: 96 pin Eurocard male

CONNECTOR MATE: 96 pin Eurocard female

PIN NO	SIGNAL	PIN NO	SIGNAL
A1	TXDA232 (OUTPUT)	C1	TXDE232 (OUTPUT)
A2	GND	C2	GND
A3	RXDA232 (INPUT)	C3	RXDE232 (INPUT)
A4	Not Used	C4	Not Used
A5	RTSA232 (OUTPUT)	C5	RTSE232 (OUTPUT)
A6	CTSA232 (INPUT)	C6	CTSE232 (INPUT)
A7	DTRA232 (OUTPUT)	C7	DTRE232 (OUTPUT)
A8	DCDA232 (INPUT)	C8	DCDE232 (INPUT)
A9	TXDB232 (OUTPUT)	C9	TXDF232 (OUTPUT)
A10	GND	C10	GND
A11	RXDB232 (INPUT)	C11	RXDF232 (INPUT)
A12	Not Used	C12	Not Used
A13	RTSB232 (OUTPUT)	C13	RTSF232 (OUTPUT)
A14	CTSB232 (INPUT)	C14	CTSF232 (INPUT)
A15	DTRB232 (OUTPUT)	C15	DTRF232 (OUTPUT)
A16	DCDB232 (INPUT)	C16	DCDF232 (INPUT)
A17	TXDC232 (OUTPUT)	C17	TXDG232 (OUTPUT)
A18	GND	C18	GND
A19	RXDC232 (INPUT)	C19	RXDG232 (INPUT)
A20	Not Used	C20	Not Used
A21	RTSC232 (OUTPUT)	C21	RTSG232 (OUTPUT)
A22	CTSC232 (INPUT)	C22	CTSG232 (INPUT)
A23	DTRC232 (OUTPUT)	C23	DTRG232 (OUTPUT)
A24	DCDC232 (INPUT)	C24	DCDG232 (INPUT)
A25	TXDD232 (OUTPUT)	C25	TXDH232 (OUTPUT)
A26	GND	C26	GND
A27	RXDD232 (INPUT)	C27	RXDH232 (INPUT)
A28	Not Used	C28	Not Used
A29	RTSD232 (OUTPUT)	C29	RTSH232 (OUTPUT)
A30	CTSD232 (INPUT)	C30	CTSH232 (INPUT)
A31	DTRD232 (OUTPUT)	C31	DTRH232 (OUTPUT)
A32	DCDD232 (INPUT)	C32	DCDH232 (INPUT)

CONNECTOR: J1, J2, J3, J4

I/O CONNECTOR TYPE: MDSM-18PE-Z10-VR25 High Density DB9 Female

CONNECTOR MATE: MDSM-9SC-Z11-VS1 High Density DB9 Male

PIN NO	SIGNAL	PIN NO	SIGNAL
1	DCD232 (INPUT)	6	Not Used
2	RXD232 (INPUT)	7	RTS232 (OUTPUT)
3	TXD232 (OUTPUT)	8	CTS232 (INPUT)
4	DTR232 (OUTPUT)	9	Not Used
5	GND		

CONNECTOR: J5

I/O CONNECTOR TYPE: MDSM-25PE-Z10-VR17 High Density DB25 Female

CONNECTOR MATE: MDSM-25SC-Z11-VS1 High Density DB25 Male

PIN NO	SIGNAL	PIN NO	SIGNAL
1	Not Used	14	TXD422- (OUTPUT)
2	TXD422+ (OUTPUT)	15	TXCLK422+ (INPUT)
3	RXD422+ (INPUT)	16	RXD422- (OUTPUT)
4	RTS422+ (OUTPUT)	17	RXCLK422+ (INPUT)
5	CTS422+ (INPUT)	18	Not Used
6	Spare+ (INPUT)	19	RTS422- (OUTPUT)
7	GND	20	SPARE+ (OUTPUT)
8	Not Used	21	Not Used
9	RXCLK422- (INPUT)	22	SPARE- (INPUT)
10	Not Used	23	SPARE- (OUTPUT)
11	Not Used	24	Not Used
12	TXCLK422- (INPUT)	25	Not Used
13	CTS422- (INPUT)		

CONNECTOR: J6, J7

I/O CONNECTOR TYPE: MDSM-25PE-Z10-VR17 High Density DB25 Female

CONNECTOR MATE: MDSM-25SC-Z11-VS1 High Density DB25 Male

PIN NO	SIGNAL	PIN NO	SIGNAL
1	Not Used	14	TXD422- (OUTPUT)
2	TXD422+ (OUTPUT)	15	Not Used
3	RXD422+ (INPUT)	16	RXD422- (OUTPUT)
4	RTS422+ (OUTPUT)	17	Not Used
5	CTS422+ (INPUT)	18	Not Used
6	DCD422+ (INPUT)	19	RTS422- (OUTPUT)
7	GND	20	DTR422+ (OUTPUT)
8	Not Used	21	Not Used
9	Not Used	22	DCD422- (INPUT)
10	Not Used	23	DTR422- (OUTPUT)
11	Not Used	24	Not Used
12	Not Used	25	Not Used
13	CTS422- (INPUT)		

CONNECTOR: J8

I/O CONNECTOR TYPE: MDSM-15PE-Z10-VR22 High Density DB15 Female

CONNECTOR MATE: MDSM-15SC-Z11-VS1 High Density DB15 Male

PIN NO	SIGNAL	PIN NO	SIGNAL
1	D0 (INPUT)	9	D8 (INPUT)
2	D1 (INPUT)	10	D9 (INPUT)
3	D2 (INPUT)	11	D10 (INPUT)
4	D3 (INPUT)	12	D11 (INPUT)
5	D4 (INPUT)	13	Not Used
6	D5 (INPUT)	14	Not Used
7	D6 (INPUT)	15	GND
8	D7 (INPUT)		